

allergic reaction to mold? dustmites? musty odors? feeling clammy?

Magnified photo of actual mold spore.

Create a Comfortable and Healthy Home!

Ultra·Aire™ XT150H



- Patent pending, optimized air-to-heat exchanger.
- Requires only 6.9 amps of electricity — half the amount of competitors!
- Environmentally-friendly R410A refrigerant.
- High-efficiency, long-life impeller fan.
- Quiet operation and superior high static pressure performance.
- Pre-configured for fresh air ventilation.
- Industry-leading 7.9 pints per kWh.
- Size for 3500 sq. ft. home.

Moisture in the home has many sources: people, pets, plants, cooking, washing, ground water, and infiltration of outside air. Too much moisture in the home can create musty odors and can also stimulate the growth of mold, mildew, bacteria, and other biological allergens.

DEHUMIDIFICATION

To avoid the problems caused by moisture, and create a comfortable environment, a dehumidifier is necessary to maintain relative humidity between 45-50% throughout the home. Only supplemental dehumidification provides indoor humidity control regardless of air conditioner operation or outside moisture conditions.



The Ultra-Aire XT150H is the first Thermo-Stor dehumidifier to utilize XT Dehumidification (extreme technology). XT DEHUMIDIFICATION OFFERS THE END-USER AN ENERGY EFFICIENCY LEVEL UNMATCHED IN THE INDUSTRY! This high capacity whole house ventilating dehumidifier delivers 150 pints per day at standard conditions using only 6.9 amps. That equates to 7.9 pints per kilowatt hour with an energy factor of 3.74. As is standard with all Ultra-Air products, the UA-XT150H will effectively dehumidify down to 56°F and will provide outstanding performance, regardless of the season.

FRESH AIR VENTILATION

Optional fresh outdoor air may be ducted to the unit via a six inch round duct. This provides fresh air to dilute pollutants and maintain high oxygen content in the air. The amount of fresh air ventilation can be regulated by a variety of dampers and controls.

AIR FILTRATION

The Ultra-Aire XT150H includes air filtration to improve indoor air quality. A MERV-11 media filter is standard. A separate, optional filter housing is available which provides additional filtration up to Merv-14 efficiency.

Specifications and Installation

Part Number:	4026480	
Blower:	415 CFM @ 0.0" WG 365 CFM @ 0.4" WG	
Supply Voltage:	110-120 VAC – 1 Phase – 60 Hz.	
Amps:	6.9	
Energy Factor:	3.74	
Operating Temp.:	56°F Min, 100°F Max	
Sized For:	3500 Square Foot Typical	
Minimum Performance at Set Conditions:		
Intake Air:	80°F, 60% RH	
Capacity:	150 Pints/Day @ 80°F/60% RH	
Pints/kWh:	7.9	
UA-XT150H Duct Connections:		
6" Round Inlet		
10" Round Inlet		
10" Outlet		
Filter Efficiency:	Standard MERV-11, (65% ASHRAE Dust Spot) Optional MERV-14, (95% ASHRAE Dust Spot)	
Power Cord:	7', 115V With Ground	
Drain Connection:	.62" ID x 8' Vinyl Hose	
UA-XT150H Dimensions:		
	Unit	Shipping
Width:	37 1/2" without collars 39 1/2" with collars	42"
Height:	22"	28 1/4"
Depth:	20 5/8"	24"
Weight:	134 lbs	164 lbs

OPTIONAL ACCESSORIES

4022220	Condensate Pump Kit
4023660	DEH 3000 Humidity Controller
4022486	Timer, 7-Day, 24 Vac, Programmable
4025287	Filter Box
4021475	Merv 11 Standard Filter 16" x 20" x 2"
4024370	Merv 14 95% Efficient Filter 20" x 24" x 4"

Optional Filter Box Dimensions:

Length:	24"
Height:	19 15/16"
Width:	14 1/4" with collars; 7 3/4" without collars
Weight:	19 lbs

Optional Filter Box Duct Connections:

6" Round Inlet
10" Round Inlet
10" Round Outlet
Optional MERV-14 (95% ASHRAE Dust Spot)

INSTALLATION MATERIALS

Control Options	Part Number
Humidity / Fan Control	4024155
Ventilation Timer / Humidity / Fan Control	4024125
DEH 3000 - Digital Control	4026570

Ducting Options

6", 2 wire 24 volt Electric Air Damper	4023672
10" Backdraft Damper	4024375
10" Starting Collar (Included w/ Unit)	N/A
6" Outside Air Intake Vent (Not Provided)	N/A
Duct Tape (Not Provided)	N/A
Large Cable Ties (Not Provided)	N/A
Insulated 6" Air Duct (Flex) - 25 ft.	4020128
Insulated 10" Air Duct (Flex) - 25 ft.	4022126

Plumbing - Not Provided By Therma-Stor

3/4" PVC Pipe
3/4" PVC Threaded Nipple
3/4" PVC Elbow
PVC Primer and Glue

Electrical - Not Provided By Therma-Stor

12-2 Non-Metallic Sheeted NM-B (Romex) Wire
20 AMP 120 Volt Single Pole Breaker
20 AMP 120 Volt Rated (3) Prong Outlet
Thermostat Wire (5Conductor, 18 AWG)
Wire Staples
Outlet Cover
Outlet Box

Preferred installation is to draw air from a separate intake duct located in the central part of the home. Duct the outlet air into the supply duct for distribution throughout the home. A backdraft damper prevents air from the supply duct from being pushed backward through the UA-XT150H when central (A/C) fan is on and the Ultra-Aire fan is off.

Therma-Stor does not recommend drawing air from the return ducting system and discharging into the supply for two reasons:

Central Fan On: The Ultra-Aire XT150H is pulling against a negative pressure (intake side) and discharging against a positive pressure (outlet side), which results in lower airflow and reduced capacity.

Central Fan Off: Discharge air may counter-flow from the supply duct directly to the return duct and not be distributed throughout the home effectively.

Ultra-Aire XT150H

Ultra-Aire™
XT150H

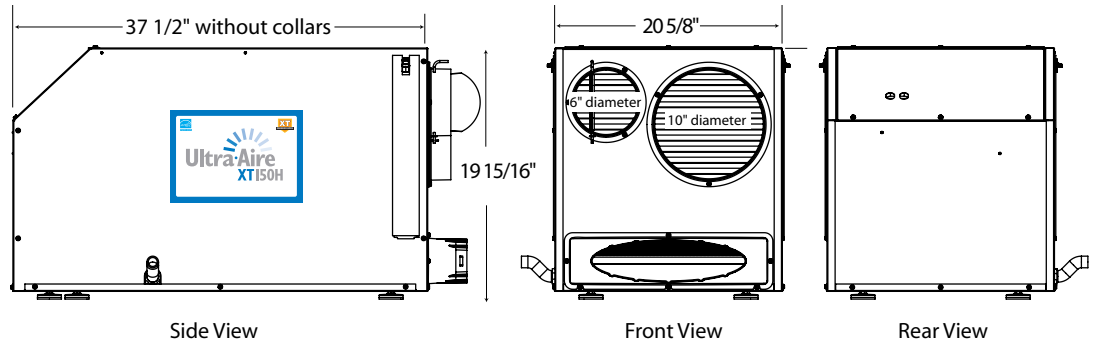

installation

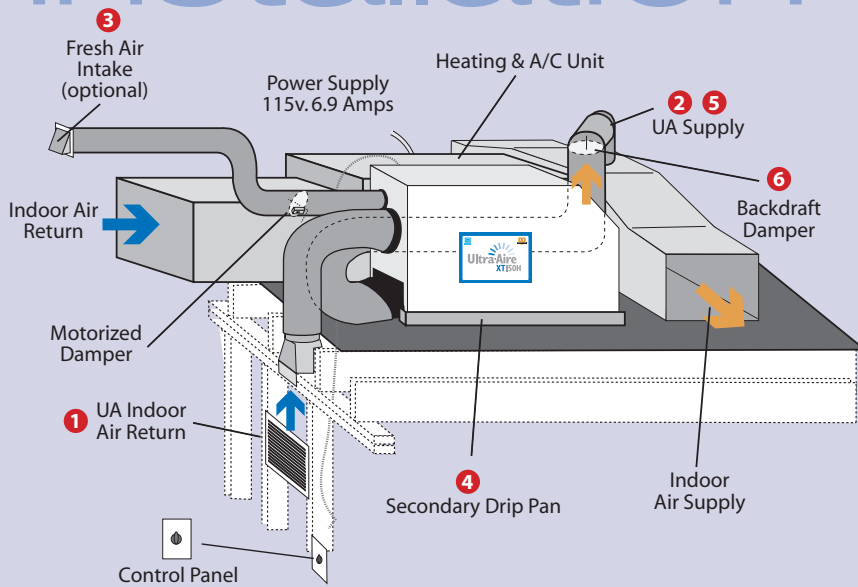

ULTRA-AIRE XT150H ATTIC INSTALLATION

1. Indoor air return should come from an open area of the first or second floor.
2. The Ultra-Aire supply should be ducted into the forced air system past the air conditioning coil. The duct connection should be perpendicular to the air flow.
3. The optional six inch fresh air intake should be located at least six feet away from any exhaust ports, such as, dryer, range hood, or combustion device exhaust. Intake location should be consistent with local codes.
4. A section of flex duct or vibration absorbing duct should be located between the connections of the Ultra-Aire ductwork and the forced air system ductwork.
5. The backdraft damper prevents counter-flow of the A/C supply air through the UA-XT150H.

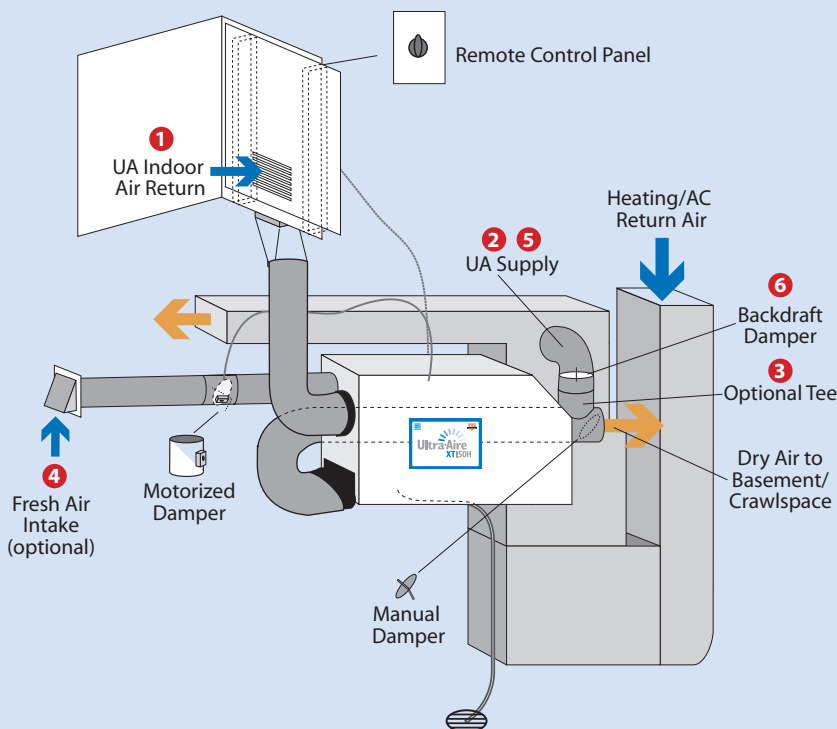

ULTRA-AIRE XT150H BASEMENT OR CRAWL SPACE INSTALLATION

1. Indoor air return should come from an open area of the first or second floor.
2. The Ultra-Aire supply should be ducted into the forced air system supply above the air conditioning coil. The duct connection should be perpendicular to the air flow.
3. An optional ten inch tee fitting with an adjustable blade damper on the straight run should be attached at the Ultra-Aire supply collar. This allows for increased air flow to the basement/crawlspace during the summer months.
4. The optional six inch fresh air intake should be located at least six feet away from any exhaust ports, such as, dryer, range hood, or combustion device exhaust. Intake location should be consistent with local codes.
5. A section of flex duct or vibration absorbing duct should be located between the connections of the Ultra-Aire duct work and the forced air system duct work.
6. The backdraft damper prevents counter-flow of the A/C supply air through the Ultra-Aire.

Notes to the installer:

EXTENSION CORDS are not recommended due to the possibility of water getting on the connection or stress on the cord. A permanent outlet is recommended 7 feet or less from the unit itself. When absolutely necessary the following extension cords may be used:

- 16 GAUGE: 0-100 feet long for tool loads up to 10 amps
- 14 GAUGE: 0-50 feet long for tool loads between 10 and 15 amps
- 12 GAUGE: 50-100 feet long for tool loads between 10 and 15 amps

DEFROST SWITCH: Opens at 19°. The defrost control will run the compressor for 45 minutes and the unit will continue to dehumidify. Then the fan runs for 15 minutes with the compressor off until the unit warms up to 50°.

CONDENSATE PUMP AND A SAFETY SWITCH: The condensate pump does have a safety switch (3.3 amps) however it cannot handle the load our unit would put on it. The entire load cannot be switched through the safety switch. A relay can be used to cut the power off to the unit or the outlet itself.

- **EXTERNAL WIRING:** Use a relay switch in conjunction with a piggy-back plug. This will cut the power off to the unit or the outlet itself. This is the easiest because no internal wiring is necessary.
- **INTERNAL WIRING:** Second option is to use relay cutting into A/C cord (turns whole unit off) or dehumidistat (still fan operation w/o compressor operation)—negative, owner may not know the unit ceased operating.

RUNNING FLEX DUCT: More than 25-50 feet of duct will decrease the efficiency of the unit by 10% or more. Minimize turns as much as possible. Also, can increase duct size or size of dehumidifier.

CHANGE FILTER every 6-12 months. MERV 14 filter every 2-3 years. Filters may be vacuumed in between. A dirty filter reduces unit efficiency.

DAMPER DOESN'T OPEN: If the damper doesn't open it could be a bad damper or bad transformer. Hook damper across secondary of transformer and plug in damper. Damper should open. If it doesn't open there is a bad damper or transformer.

REFRIGERANT CONNECTIONS: All dehumidifiers have a service valve on the refrigeration system to allow technicians to check the charges with gauges, if necessary.

HIGH TEMPERATURE OPERATION: Use of a thermostat is recommended in attic applications that exceed 100°. WW Grainger has an adjustable thermostat that plugs into the 115V outlet. The dehumidifier plugs into the thermostat that is set for 100° F and during the hottest part of the day the thermostat will stop the dehumidifier from running.

VIBRATION NOISE: If there is vibration in the cabinet of the dehumidifier, remove the cover and check the compressor/tubing for contact with the case. Most of our units have a shipping support band on the compressor. This should be removed. Adjusting the compressor bolts to maximize the flexing of the compressor will reduce vibration transfer. In addition, ¾" plywood cut to fit the three flat surfaces of the dehumidifier will reduce noise significantly.



4026208

Do you know the relative humidity levels in your home?

The Humidity Alert™ was designed to discriminate between occasional periods of high humidity and the prolonged periods that create a risk of unhealthy biological activity. It's a simple, inexpensive device that monitors temperature and relative humidity conditions and records data that is known to contribute to **wood rot, mold growth, musty odors and increased pest activity.**

Easy to use:

1. Place the meter in the desired space.
2. Collect the necessary humidity data.



4023660

Ultra-Aire Digital Controller

You will enjoy the comfort that comes with precise regulation of your indoor environment with our new **DEH 3000 Digital Control**. This control will allow you the ability to monitor and control relative humidity levels in your home. The DEH 3000 is designed to accommodate your personal comfort level.

This unit replaces the DEH 2000 Digital Control. To be used with the Ultra-Aire Whole House Ventilating Dehumidifiers.